

Excellence and productivity in digital textile printing



Experience the Total Textile Solution

Total Textile Solution is the fully integrated system for industrial digital printing on textiles with the Monna Lisa series, where all components follow the same process to guarantee the best printing results and the utmost customer satisfaction. Epson has achieved this goal by building the necessary skills and know-how over the years by initially collaborating with and then acquiring as part of the Epson Group two leading companies located in the “Digital Textile Valley” area of Como: F.lli Robustelli, who originally engineered the Monna Lisa system using Epson Micro Piezo print heads, and For.Text, a trusted provider of dyes, thickeners, specialty for pre- and post-treatment and the Genesta inks. In December 2020 F.lli Robustelli incorporated For.Text under the new merged company name of Epson Como Printing Technologies. Monna Lisa, now branded as an Epson product, is the outcome of a story that began in the early 2000s and has brought Epson at the forefront of the industrial digital textile market.

Our story

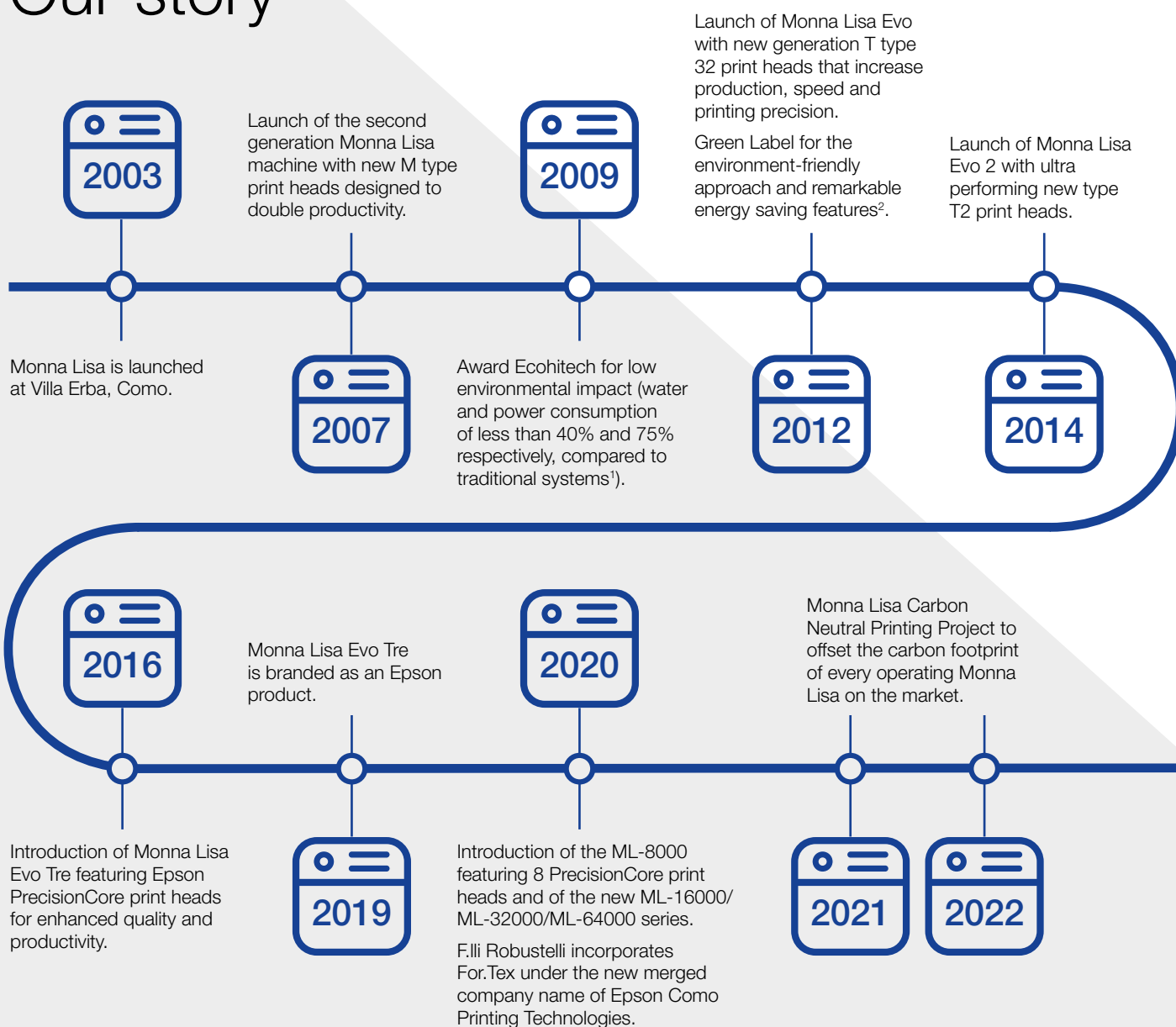

¹ Source: *Water and electricity consumptions in textile printing. A comparison between conventional and ink jet technologies. The final results.* Como Textile Cluster Monitor LIUC University, Italy, 2008.

² The Green Label certification is a project promoted by ACIMIT (Association of Italian Manufacturers of Machines for the Textile Industry), supported by the Ministry for Economic Development and by the Institute for Foreign Trade.

Fields of application



Haute couture fashion

Monna Lisa provides clothing designers from leading Italian and international fashion houses with a wealth of colours and shades to create unique items that combine both innovation and artisanry.



Fast fashion

Monna Lisa endows the productivity demanded by fast fashion retailers with its typical quality standards, for collections that are more than just seasonal, inspired by developing trends in the fashion market.



Fashion accessories

Natural fabrics and innovative yarn for scarves, ties, shoes or handbags are enriched with traditional motifs and original patterns featuring precision of detail and unparalleled repeatability achievable only with Monna Lisa.



Sportswear

Thanks to extensive ink testing, Monna Lisa provides excellent quality even on innovative technical fabrics developed to meet increasingly sophisticated communication and/or functional needs.



Home textiles

Curtains, sofa and armchair fabrics, home linens and contract furnishing fabrics are all produced with different types of yarn. Monna Lisa's extensive variety of inks produces fabrics embellished with designs and original colours that last through the years.



Textile printing workflow

The diagram below illustrates the textile printing flow highlighting the advantages of digital over traditional processes. The latter entails higher environmental impact, higher costs, more production waste, and less flexibility than digital printing.



Traditional printing

Digital printing

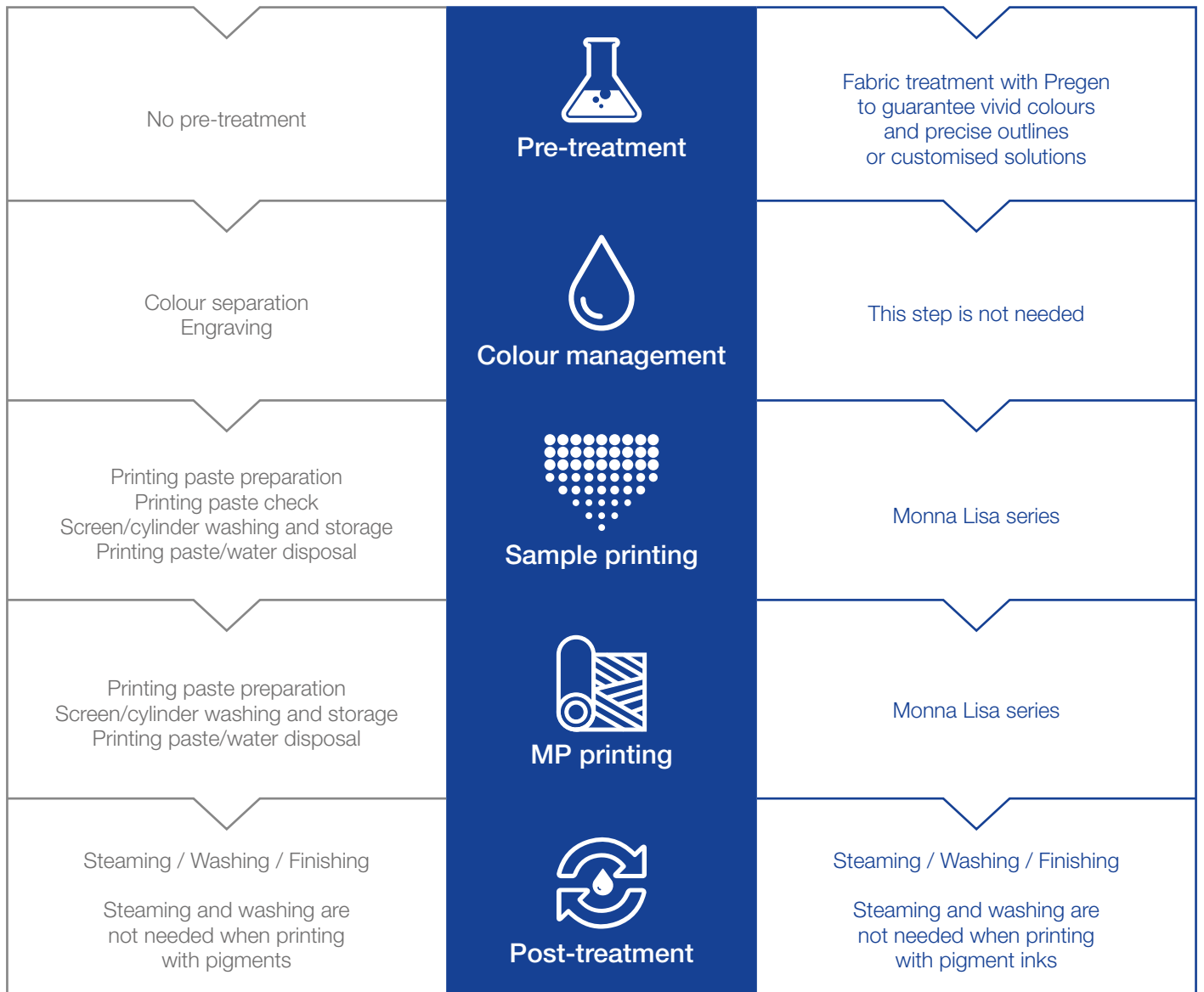

Printing process with the Monna Lisa series

Industrial digital printing on textiles is part of a broader process, ranging from creative concept to fabric pre-treatment and finishing. The diagram below illustrates the whole printing flow with the Monna Lisa series.

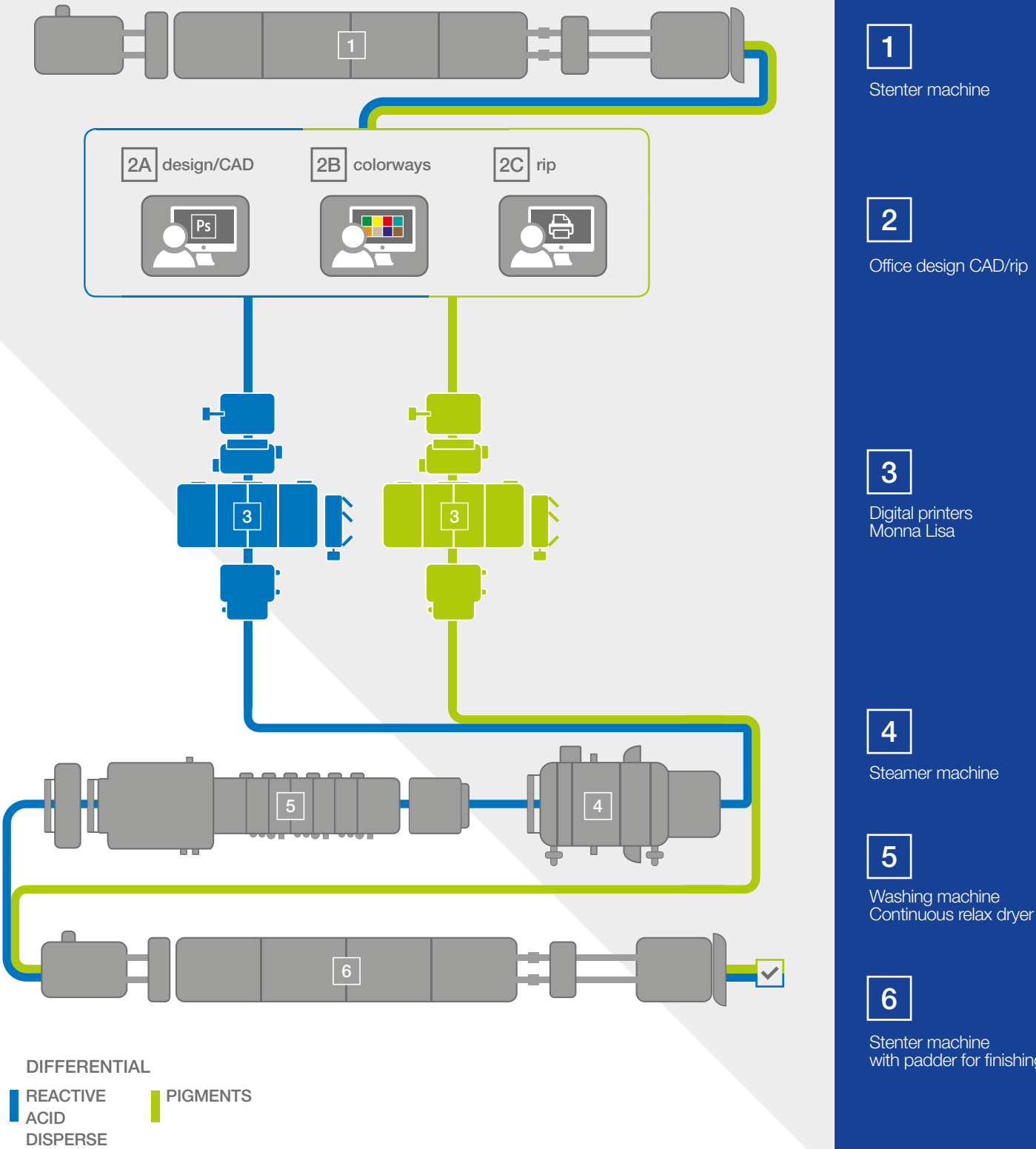

Monna Lisa: evolution, development and innovation

Monna Lisa represents the evolution of Epson industrial digital textile printers and has become a reference standard for high quality printing in such fields of application as haute couture & fast fashion, accessories, home textiles and sportswear.

Characterised by the flexibility and productivity typical of digital technology, it is the right choice for an increasingly dynamic market, which demands swift responses to shifting needs.

Flexibility and reliability

One of the most important qualities of Monna Lisa is its flexibility. It provides users with a single printer to meet a variety of different production needs. It handles different types of inks, prints on any type of fabric and reproduces the simplest or most complex designs with uncompromising quality, speed and repeatability.

Inks are available in colour racks of different capacities (3 or 10 L), with the possibility to swap ink types.

Moreover Monna Lisa is available in several configurations, differentiated by the number of print heads and printing widths.



Features

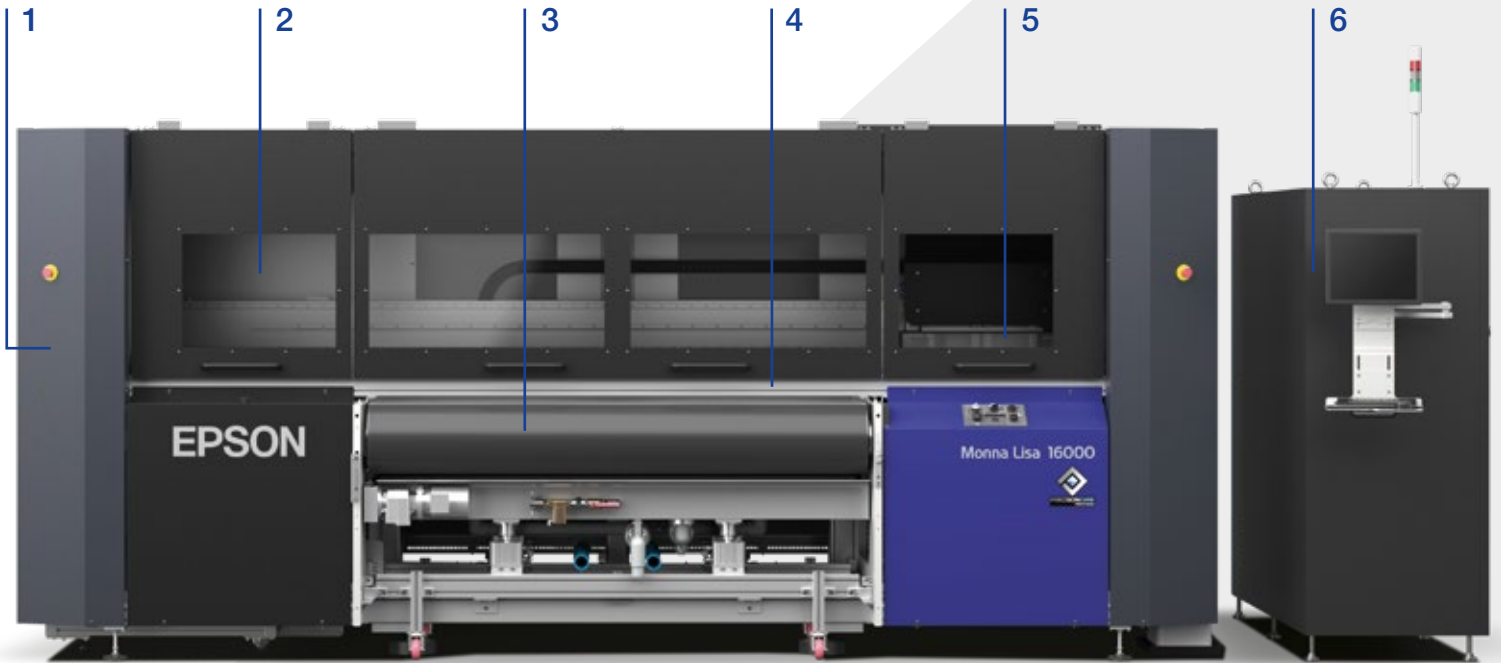

1. Ink management

The exclusive vacuum-packed degassed ink management system is designed to achieve the maximum efficiency while minimising ink waste. Ink racks are available in different capacities (3 or 10 L).



4. Flexibility

The broad resolution range and interlacing methods ensure high quality prints on any fabric type.



2. Facilitated access

Easy and safe access to the machine for inspections, management and maintenance operations.



5. PrecisionCore print head array

The new print head array combines quality, precision, speed and reliability with unprecedented results. It is the latest evolution of Epson's proprietary Micro Piezo printing technology.



3. Fabric feeding

The efficient fabric feeding system is designed to ensure highly precise printing speed and quality.



6. Epsom Edge Print Pro X

Epsom Edge Print Pro X is the RIP software specifically designed to get the most out of your Monna Lisa. The freedom to use other RIPs or textile CADs is one of the printer's main flexibility features.

Digital textile printing is easy on the environment

There is a consensus that inkjet printing is the future of textile printing.

Advantages such as lower production costs and the possibility to customise short runs are undeniable. But there's more. The Total Textile Solution system offers printing companies and other operators in the textile production chain considerable benefits in terms of environmental impact and compliance with the laws, regulations, certifications and restrictive specifications produced by customers and brands in the fashion industry.



A study comparing a production cycle using the Monna Lisa series and one using a rotary press, carried out at a printing company equipped with both kinds of technology installed, shows the advantages of inkjet technology in terms of carbon footprint and water consumption. In particular, the reduction in water consumption (-27%) has two important environmental benefits: reduction in the volume of wastewater sent to treatment plants and reduction in the

amount of energy needed to heat process water. In terms of carbon footprint, the conventional rotary system generates 139.56 kg of CO₂eq, while the digital system produces 85.66 kg of CO₂eq.*

*Source: TSC Booklet #3. *Digital Printing and Sustainability*. Italy, 2017. Comparison between printing 1,000 metres of fabric with the Monna Lisa series and with a rotary press in a printing company equipped with both technologies.

Our environmental certifications



All types of Genesta inks have been granted the ECO PASSPORT certification by OEKO-TEX®, assurance that they meet the strict human-ecological standards for chemicals.



The bluesign® system is the solution for a sustainable textile production. It ensures that the final textile product meets very stringent consumer safety requirements worldwide and also provides confidence to the consumer to acquire a sustainable product. It applies to Genesta Acid inks.



GOTS Approved Additive
Approved by Ecocert Greenlife
GOTS-ECOCERT-08-01219

Genesta RE-N Reactive inks (except one of Grey: Grey RE-N), Genesta AC Acid inks (except Black AC-N / Grey AC-N) and Genesta PG-2 Pigment inks have been GOTS approved by ECOCERT. GOTS is the worldwide leading textile processing standard for organic fibres, including ecological and social criteria, backed up by independent certification of the entire textile supply chain.

Total Textile Solution: technology inside

Powered by PrecisionCore



Driving the Monna Lisa is a new print head array featuring Epson's advanced PrecisionCore technology. Taking the example of 128 PrecisionCore MicroTFP print chips configured as 32 four-chip print heads, the array provides 12,800 nozzles* for each colour and outstanding productivity. While being highly durable, it is also designed for easy maintenance to minimise downtime. PrecisionCore is the outcome of constant research and development to achieve greater efficiency, quality and reliability in Direct-to-Fabric printing. Our range features models from 8 to 64 print heads.

* In 8-colour configuration

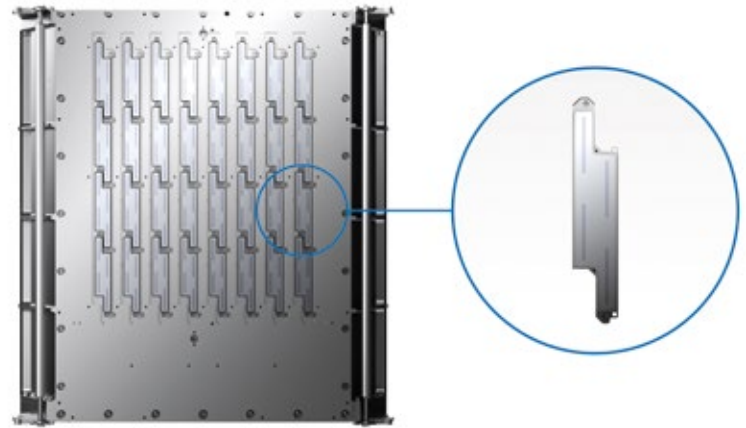

32 heads

4-chip print head

Symmetrical colour alignment for maximum print quality and productivity

Symmetrical colour alignment ensures consistent colour overlap order is maintained during bidirectional printing. As a result, colour and pattern reproduction are exceptionally uniform, and even areas of solid colour and fine geometric patterning can be beautifully rendered while maintaining high throughput.



Fabric pre-treatment with Pregen

Fabrics to be printed, whether using traditional or digital, must be carefully prepared by cleaning them of any impurities that might compromise printing. They also have to be hydrophilic, flat, straightened and stabilised in dimensions.

In addition to all these requirements, in order to be ready for digital printing, the fabric must be pre-treated to:

Allow the fixation of the dye contained in the ink to the textile substrate

Optimise the intensity and brilliance of the prints

Control the spreading of the ink on the fabric, so improving the printing definition

Support the ink absorption on the fabric, so making drying easier

Support the penetration of the dye contained in the ink



In general, fabric preparation is essential for all the digital printing processes, except for pigment printing. It is optional for digital printing with pigment inks but it's useful in order to obtain deep and brilliant shades.

It may be applied using various application systems, such as padding, all over printing or spraying. Padding is the most common method thanks to ease of use and optimum dimensional control of the fabric.

After the application of the Pregen preparation for digital printing, the fabric must be dried.

In case of preparation meant for printing on silk, wool, polyamide or other cellulose fibres, the drying temperature should not exceed 105°C and drying shall be made in such a way to have a residual humidity on the material of approx. 50% of the nominal rate of recovery.

Lower residual moisture values waste energy and may lead to thermal degradation of some preparation components and consequent loss of colour yield.

In the case of polyester fibres, there is no temperature restriction, but a too quick drying could negatively affect the printing definition.

The table on the following page lists the main types of Pregen according to their characteristics.

PREGEN	FIBRE / INK	COLOUR YIELD	PENETRATION	DEFINITION	NOTES
A 1005	Silk, polyamide with Genesta AC				
A 800 S	Silk, polyamide with Genesta AC				Suitable for fabrics that absorb a lot of ink
AT-6	Polyamide with Genesta AC				
TR/C	Polyamide with Genesta AC				Mainly suitable for elastic jersey
A WOOL	Wool with Genesta AC	 on chlorinated wool			
RCA	Cellulose, silk with Genesta RE-N				Alkali must be added (carbonate or bicarbonate)
RCA-B	Cotton, silk with Genesta RE-N				Ready-to-use version containing bicarbonate
RCA-TB	Viscose with Genesta RE-N				Ready-to-use version containing bicarbonate
R16	Cellulose, silk with Genesta RE-N				
RBA	Cellulose with Genesta RE-N				
DS 6040	Polyester with Genesta DS				
DT20	Polyester with Genesta DS				
DDS	Polyester with UltraChrome DS				Direct printing procedure with sublimatic inks
PCA	All with Genesta PG				Low print coverage
PCC	All with Genesta PG				
TH	Polyester with Genesta DS				Concentrated product to be diluted with water
TH	Cellulose and silk with Genesta RE-N				Base to be mixed with alkali, urea and OXIDOL PA
RTW	Wool with Genesta RE-N	 on chlorinated wool			

KEY Acceptable Fair Good Very good

Printing with Genesta inks

GENESTA

Genesta inks have been developed specifically for the Monna Lisa series, to allow precision, reliability and durability of fabric prints. Genesta inks - Acid, Reactive, Disperse and Pigment - provide the highest quality on any fabric.

The exclusive Monna Lisa ink management system limits waste and the suction system is designed to permit the use of degassed vacuum bags.

Ongoing activity of Research & Development continues to expand the range of inks or colours, and to improve printing quality.



Acid inks GENESTA® AC

Genesta AC inks may be used for printing on properly prepared silk, wool and PA fabrics using the Monna Lisa series printer.

Drying is easy and the dried fabrics can be stored before steaming, which is performed using saturated steam at 102°C for 30 minutes (40 minutes for wool).

In order to eliminate the unfixed ink and the preparation, specific washing treatments are performed according to the type of the printed fabric.

Genesta AC inks are available in the following types:

- | | | |
|------------------------|---------------|------------|
| Fluorescent flavine AC | Vermillion AC | Cyan AC-H |
| Yellow AC-H | Red AC-H | Grey AC-N |
| Orange AC-F | Rubine AC | Black AC-N |
| Magenta AC | Blue AC | Across |
| Fluorescent pink AC | Cobalt AC | |

Reactive inks GENESTA® RE-N

Genesta RE-N inks may be used for printing on properly prepared cotton, viscose, linen and other cellulose fabrics, silk and wool using the Monna Lisa series printer.

Drying is easy and the dried fabrics can be stored before steaming, which is performed within 24 hours after printing with saturated steam at 102°C for 12-15 minutes in case of cellulose fibres, 20 minutes for silk and 30 minutes for wool.

Special care must be taken to ensure the steam has the proper characteristics: it must be free of any nitrogenous compounds which are often used as additives in boilers or may remain as residues of previous steaming of fabrics printed with acid inks.

In order to eliminate the unfixed ink and the preparation, specific washing treatments are performed according to the type of the printed fabric.

Genesta RE-N inks are available in the following types:

- | | | |
|--------------|-----------|------------|
| Yellow RE-N | Red RE-N | Grey RE-G |
| Orange RE-N | Blue RE-N | Black RE-N |
| Magenta RE-N | Cyan RE-N | Across |
| Crimson RE-N | Grey RE-N | |

Disperse inks GENESTA® DS

Genesta DS inks may be used for printing on properly prepared PES fabrics using the Monna Lisa series printer.

Drying is a bit more difficult than the other inks because polyester has low absorption capability. So, we suggest using a paper sheet to avoid back staining.

The dried fabrics can be stored before the fixation, that can be carried out as follows:

- using heated steam at 170°C for 10 minutes (suggested method)
- using air at 180°C for 2 minutes

In order to eliminate the unfixed ink and the preparation, specific washing treatments are performed.

Genesta DS inks are available in the following types:

- | | | |
|--|---|---|
|  Yellow DS-E |  Red DS-E |  Grey DS-F |
|  Orange DS-E |  Blue DS-E |  Black DS-F |
|  Magenta DS-E |  Cyan DS-E | |









Pigment inks GENESTA® PG-2

Genesta PG-2 inks may be used for printing on properly prepared cotton, viscose, linen, other cellulose and their blends with PES and PA fibres using the Monna Lisa series printer. The best results, especially for colour yield and brilliancy, are obtained by printing on fabrics pre-treated with Pregen PCA or PCC.

Post-print drying must be calibrated to properly initiate the resin cross-linkage process and consequently the temperature on the fabric must be at 150°C for at least 1 minute. In fact, the Genesta PG-2 inks contain a small amount of binder which is necessary to make the pigment resistant to wetting but not to washing with detergents.

Colour fastness is then ensured by post-treating the fabric with special products. After applying the post-treatment, the resin must be baked again at 160°C for 2 minutes.

Genesta PG-2 inks are available in the following types:

- | | | |
|--|--|--|
|  Yellow PG-2 |  Red PG-2 |  Grey PG-2 |
|  Orange PG-2 |  Cyan PG-2 |  Black PG-2 |
|  Magenta PG-2 |  Green PG-2 | |



ATRAFIX blanket adhesives

In order to assure optimum digital printing, it is necessary that the printer blanket must have the right degree of tack. The Monna Lisa printer blanket requires application of a permanent adhesive. The ATRAFIX ML series was created specifically for this purpose. We are talking about solvent-based acrylic co-polymers that may be applied to the blanket using the supplied squeegee.

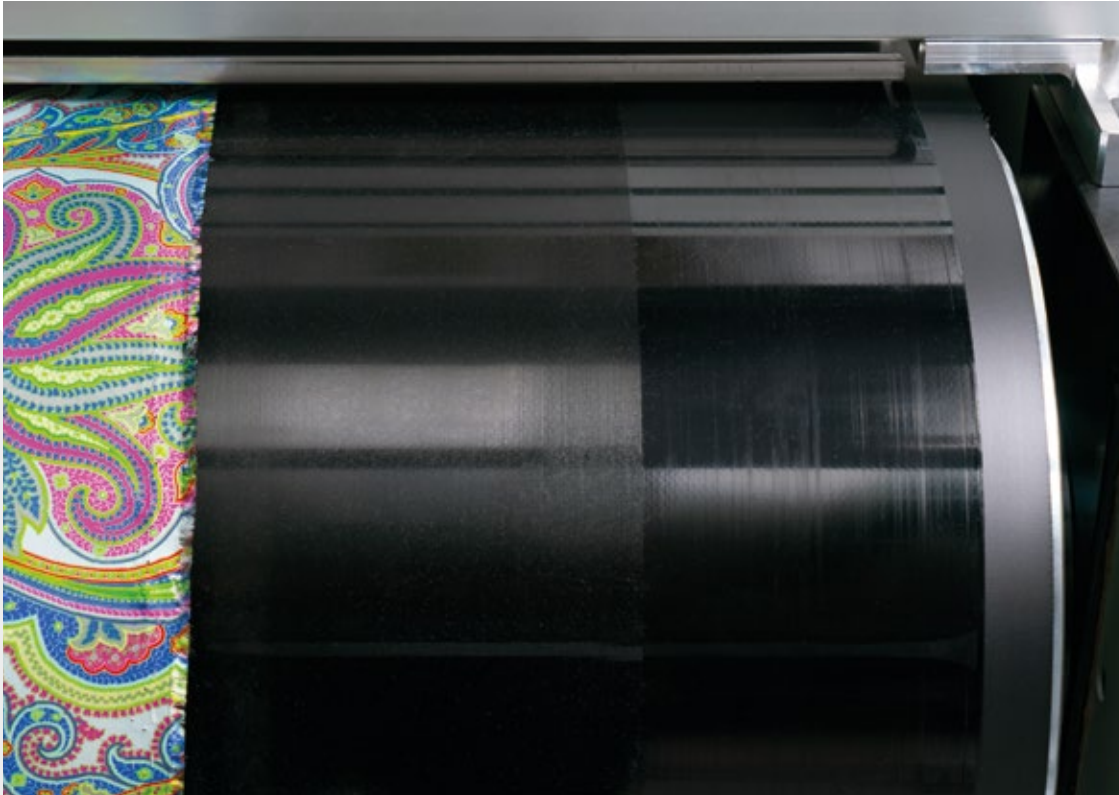

For example, the blanket may be prepared by spreading a bottom layer of ATRAFIX ML/T and applying a top layer of ATRAFIX ML/S or ATRAFIX ML/K.

The first one creates a soft and high-tack film (more suitable for cellulose fibres) while the second one creates a harder and high-tack film (more suitable for silk and synthetic fibres).

The adhesives may be mixed in order to obtain an intermediate characteristic as needed by specific production requirements.

Periodical washing of the blanket is recommended using REMOVER NLP which allows to remove the dirt so refreshing the initial adhesiveness. Washing the blanket using only water, by turning on the rotating brushes placed in the lower side of the blanket, is not effective.

When the adhesive needs to be totally replaced, the surface layer has to be restored by using additional ATRAFIX ML/S and ATRAFIX ML/K. We suggest periodically refreshing the blanket, removing the adhesive layers by using ADHESOLV (environmental friendly and not flammable solvent).

THERMOPLASTIC ADHESIVE

PRODUCT	VISCOSITY	SOLID CONTENT	TACK	ADHESION	FILM HARDNESS
ATRAFIX ML/T	1000 cps	21%	>30°C	Very good	Hard

PERMANENT ADHESIVES

PRODUCT	VISCOSITY	SOLID CONTENT	TACK	ADHESION	FILM HARDNESS
ATRAFIX ML/S	1450 cps	21%	High	Good	Soft
ATRAFIX ML/K	1000 cps	22%	Very high	Very good	Hard

LEVELLING RESIN

PRODUCT	VISCOSITY	SOLID CONTENT	TACK	ADHESION	FILM HARDNESS
RESIN NF	500 cps	22%	No	Very good	Hard

DETERGENT AND REFRESHING AGENT

PRODUCT	CONCENTRATION
REMOVER NLP	78%
ATRACLEAN ML	78%

STRIPPING AGENT FOR THE REMOVAL OF RESINS AND ADHESIVE FILMS

PRODUCT	CONCENTRATION
ADHESOLV	100%

Total Textile Solution: printing flow

Post-treatment

Traditional finishing

In order to obtain the desired hand-touch, all the commonly used finishing products may be applied on digital printed fabrics according to the specific fibre.

We suggest using quality products like:

FORSIL MCS

softening silicon microemulsion

FORSIL HYR

hydrophilic and cross-linking silicon micro-emulsion

MONSOFT IO

non-yellowing concentrated cationic softener

FORPUR 48

very soft polyurethane resin

RESIVIN NN

thermoplastic resin for full and hard hand effect

RESIVIN AT

cross-linkable resin for full and hard hand effect

FORDEEP SOF

darkening silicon softener

FORFLEX PE

polyethylene wax for full hand effect and improved sewability

FORFLEX ZF

anti-crease glyoxalic resin for full hand effect

OXAL XS / XH / R3N

cross-linking agents



Steamer machine



Washing machine

Washing

FORPON SCR / TEXIPRINT B / TEXIPRINT GA / TEXIPRINT CS

soaping agents

FORFIX HFN-I

fixing agent for silk and wool

POLIFEN P

fixing agent for polyamide



Washing machine



Stenter machine

Innovative finishing

In addition to the traditional finishings, new “wellness” finishings are available.

They allow to apply substances onto the fabrics to enhance the interaction between the final user and the surrounding environment bringing particular benefits:

AROMA AQUALITE

fragrance release (lavender, rose, lemon, sandal, etc)

PRETHERMO

thermoregulator at 25°C or 31°C

FORAGE EL

release of elagic acid (anti-inflammatory)

FORAGE GL

release of linoleic acid (moisturizing)

ANTIFIAMMA PES

flame retardant for PES

FORGUARD 3001

water/oil-repellent treatment

FORGUARD NF

fluorine-free water-repellent treatment



Research and technical support

Industrial textile printing is an expression of high craftsmanship that requires continuous support and attention, as well as tailored, precise, timely and effective solutions. An important goal of our Total Textile Solution is to pursue continuous improvement, on the one hand helping customers to solve critical issues, and on the other exploring the technical and expressive potentials of digital printing on fabric, so as to stay one step ahead in the quest for innovation.

We have thus instituted different research, training and technical support centers that liaise directly with potential customers or printing companies to develop customised solutions based on specific requirements.

Chemical laboratory

The Chemical Laboratory* is equipped with all the tools and equipment necessary for objective fabric testing and to provide printing workshops with a reliable response to any disputes concerning appearance, fastness and any other technical or application issue. Technicians specialised in traditional/digital printing, preparation, dyeing, finishing and textile chemistry thoroughly analyse every chemical-textile issue that may arise during printing or pre- and post-treatment. Chemical engineers research innovative solutions with regard to ink features and printing effects.



Light fastness



Perspiration fastness



Rubbing fastness



Water fastness

* The Chemical Laboratory, the Textile Solution Center and the Innovation Research Lab are located at Epson Como Printing Technologies local premises in Fino Mornasco (CO). The Printing Research Center is located at Epson Como Printing Technologies headquarter in Villa Guardia (CO).



The Textile Solution Center is the facility entirely dedicated to research, assistance, training and promotion in industrial digital textile printing. The Center* addresses the entire digital printing production process - from pre- to post-printing - on an industrial scale, bringing creative ideas to life and developing customised solutions to respond to any issue. In short, a one-stop place for exploration, understanding, selecting and experimenting.

In addition to its assistance and research work, the Textile Solution Center also trains the designers and stylists of tomorrow, in collaboration with universities and design schools, as well as potential Monna Lisa customers, with a view to providing a thorough understanding of textile printing and of the potentials offered by digital printing. Moreover, the Center actively promotes digital culture, through events, webinars, conferences and courses. The Textile Solution Center has also created the series of books titled "Beyond the silk road".

In June 2019, Epson opened a new textile solution center called "TSC Asia" at its Fujimi Plant in Japan. Designed to accelerate the global expansion of the digital textile printing business, TSC Asia is equipped to handle every step in the textile printing process, including textile pre- and post-treatment. Like the facility operating in Como, TSC Asia supports digital textile printing by conducting research and development and by using actual textile printers to produce samples for customers in Japan and throughout Asia.



Textile Solution Center Como



Textile event in Como



Textile Solution Center Asia

INNOVATION Research Lab

A facility* researching and developing new inks for industrial digital printing, the Innovation Research Lab is equipped with state-of-the-art technology and staffed by a team of highly-skilled researchers.

PRINTING Research Center

The Printing Research Center* aids product development of core inkjet devices, ensuring the continued development of the highest quality textile printers for Epson.

Epson Como Printing Technologies Srl

Headquarter:

Via Firenze, 3
22079 Villa Guardia - CO - Italy
Tel +39 031-483319

Local premises:

Via Livescia, 10/12 e 11
22073 Fino Mornasco - CO - Italy
Tel +39 031-927988

www.epsoncomo.it
www.epson-monnalisa.eu

Epson Europe B.V.

Atlas Gebouw, Hoogoorddreef 5
1101 BA Amsterdam, The Netherlands



Trademarks and registered trademarks are the property of Seiko Epson Corporation or their respective owners. Product information is subject to change without prior notice. Pictures in this document are shown for illustrative purposes only.

EPSON®